

SEE L1.00 FOR SUBMITTAL REQUIREMENTS

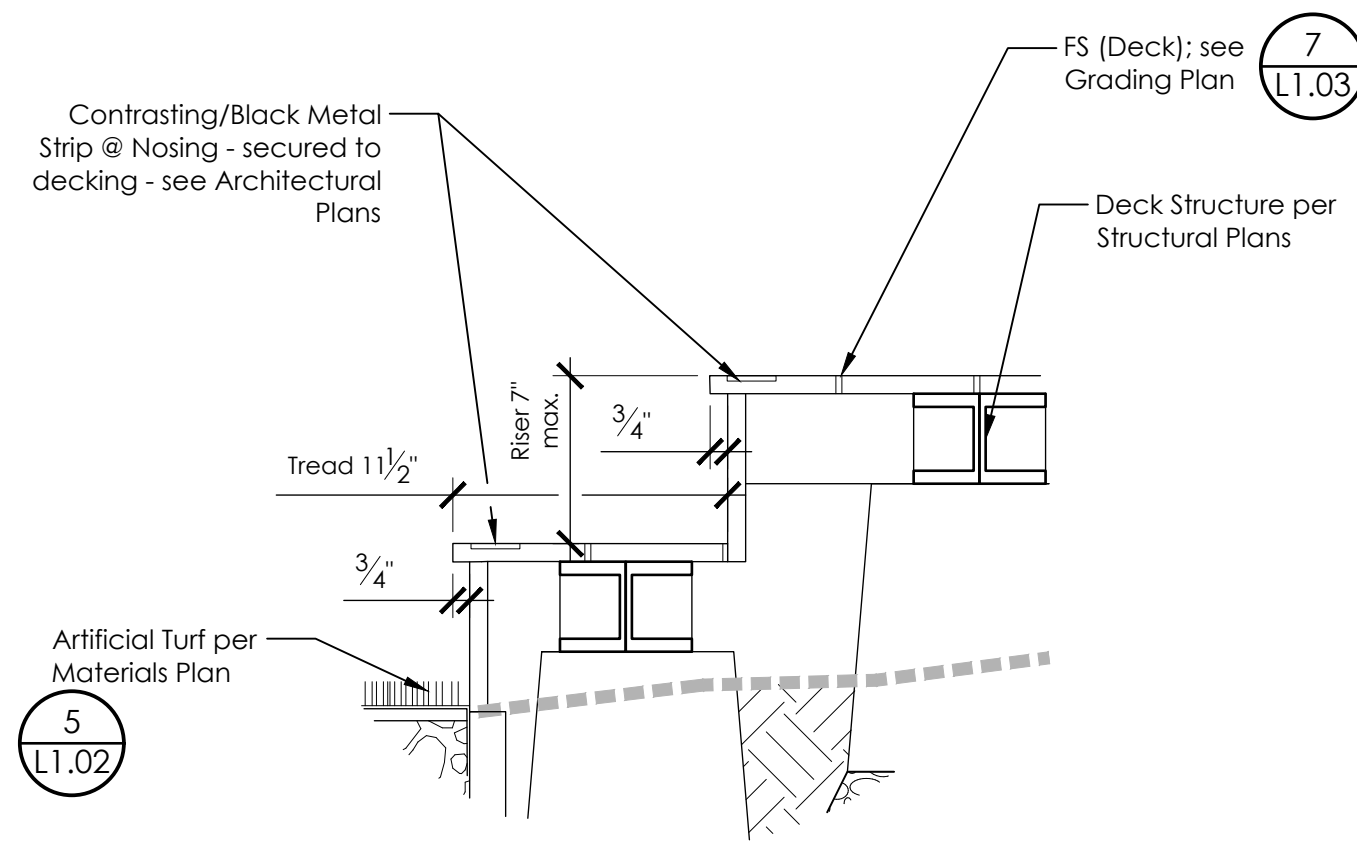

- NOTES:**
- 1) Refer to Demo Plan for tree protection and notes.
 - 2) Refer to Materials Plan for decking material.
 - 3) Refer to Structural Plans for deck structure, footings, and other information.
 - 4) Refer to Grading & Drainage Plan for finished surfaces, drainage.
 - 5) Refer to Artificial Turf Mfr. for additional information and details.

7 DECK NOSING
NOT TO SCALE P-IN-SCL-74

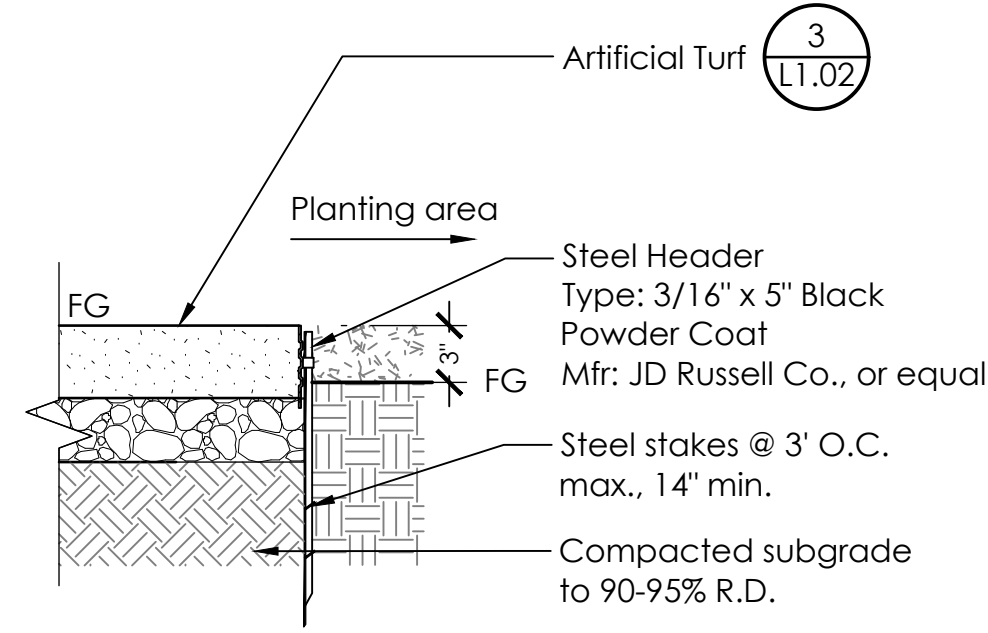

- NOTES:**
1. Compact grades adjacent to edging to avoid settling.
 2. Corners - Cut base of edging up half way and form a continuous corner.
 3. Stake on inside of planting area when adjacent to artificial turf areas.

6 METAL HEADER
NOT TO SCALE P-IN-SCL-05

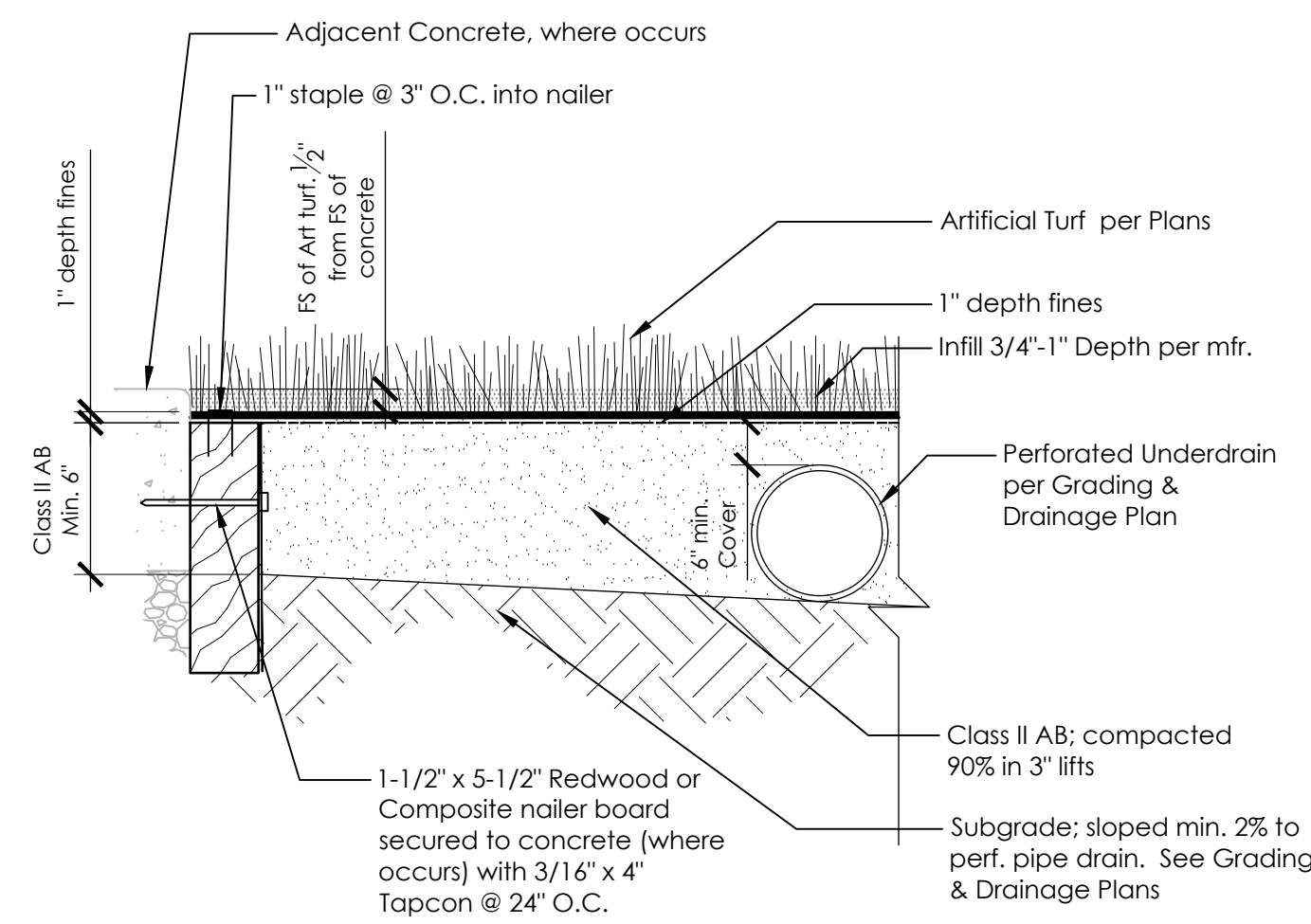

- NOTES:**
1. Installation to be completed in accordance with manufacturer's specifications.

4 ARTIFICIAL TURF @ CONCRETE PAVING
DO NOT SCALE P-IN-SCL-23

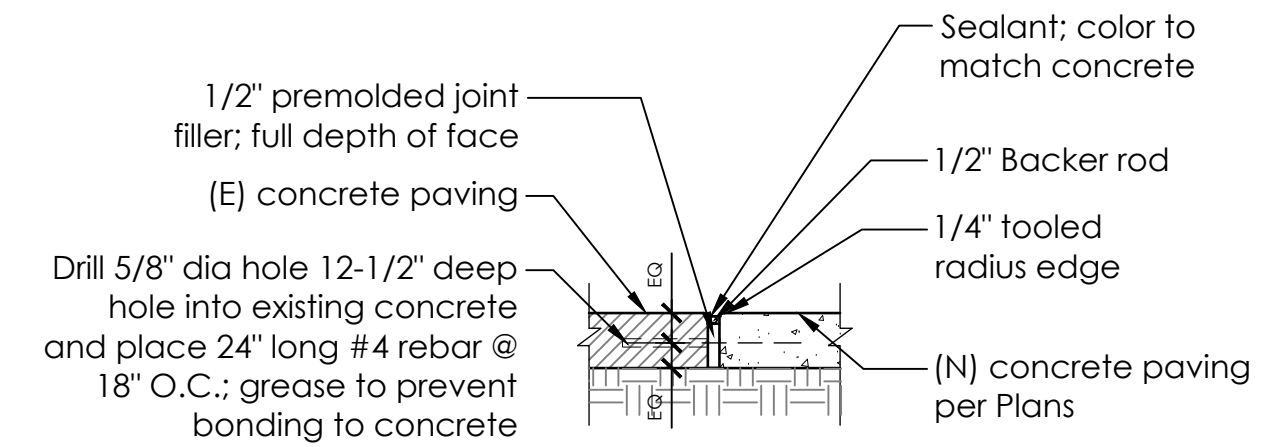
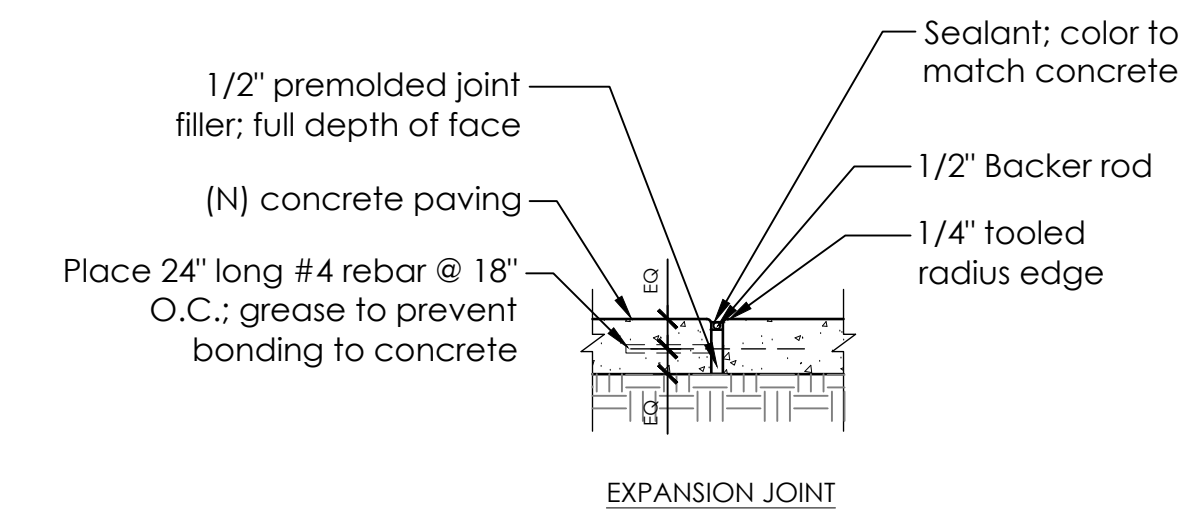

1 EXPANSION JOINTS
NOT TO SCALE P-IN-SCL-67

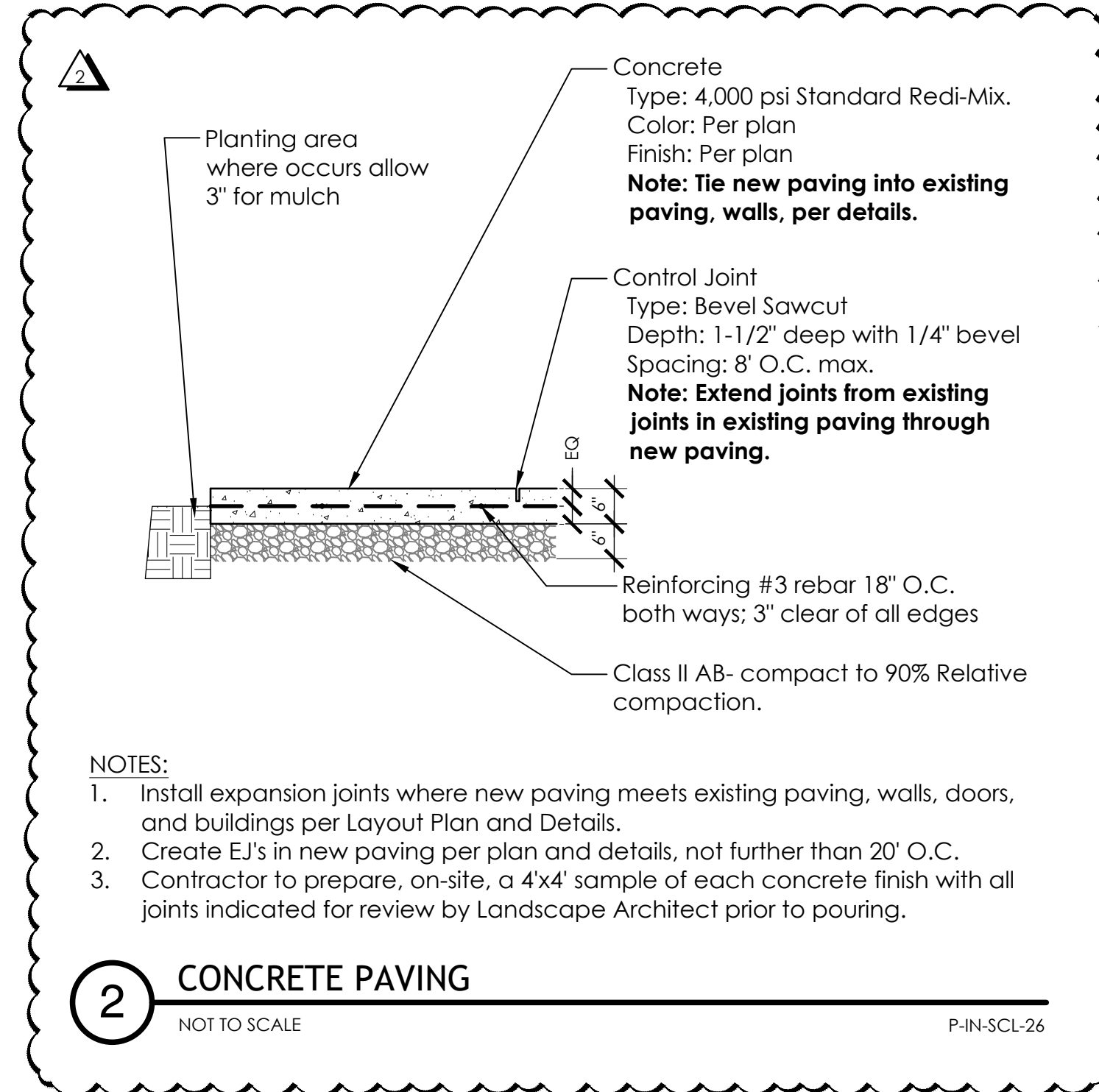

2 CONCRETE PAVING
NOT TO SCALE P-IN-SCL-26

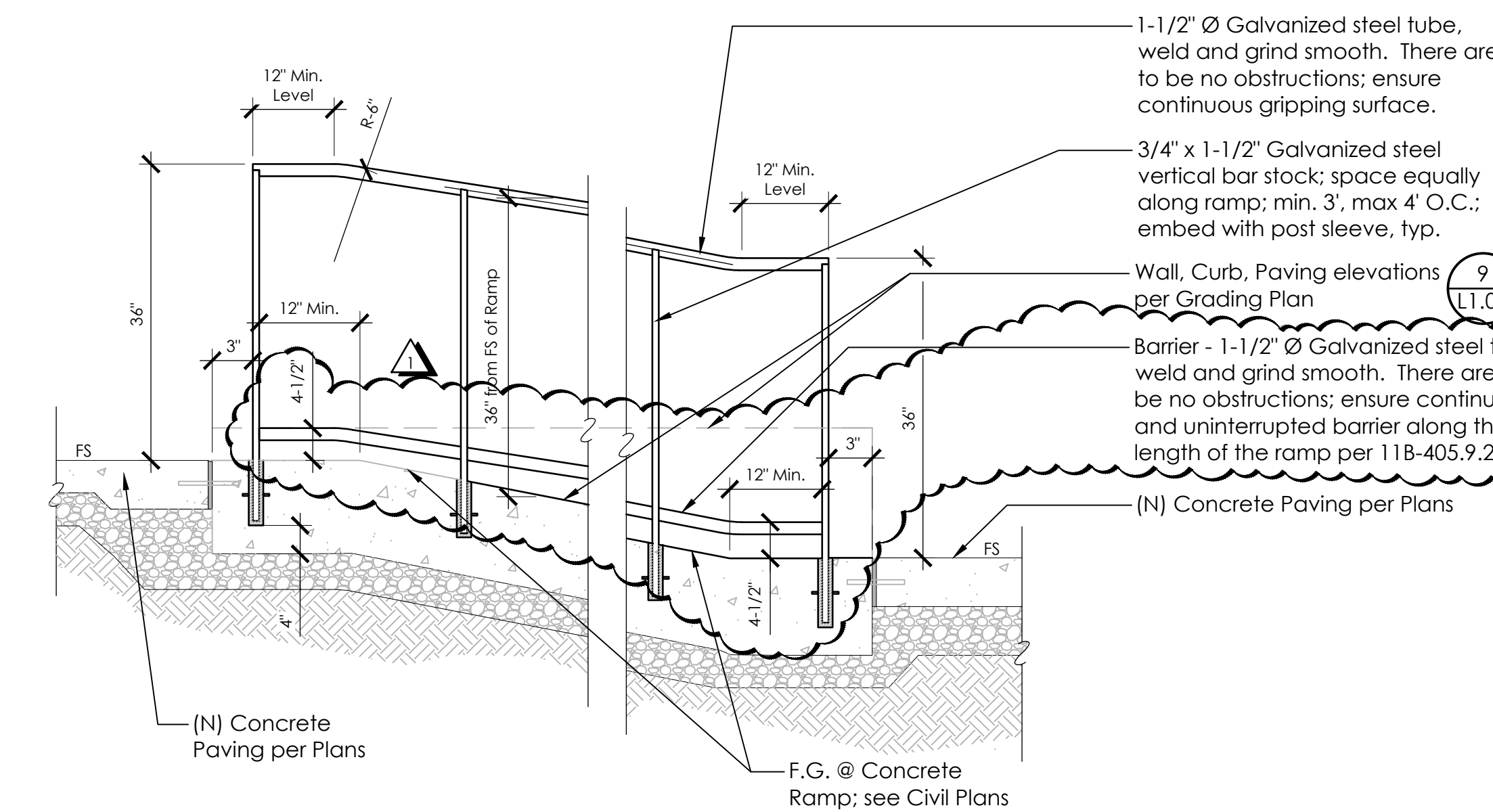

- NOTES:**
1. Refer to Materials Plans for alignments, finishes, locations of walls, curbs and handrails. Refer to Grading and Drainage Plans for spots, slopes, grades.
 2. Grind all welds smooth.
 3. All railings to be electro-polished 304SS.
 4. Radius all bends and cope to fit pipes at all intersections.
 5. Ramp and Handrails to meet current (at time of installation) CBC section 11B504 and 505 for accessibility requirements.
 6. Contractor to provide shop drawings for review by Landscape Architect.

8 HANDRAIL AT RAMP
DO NOT SCALE

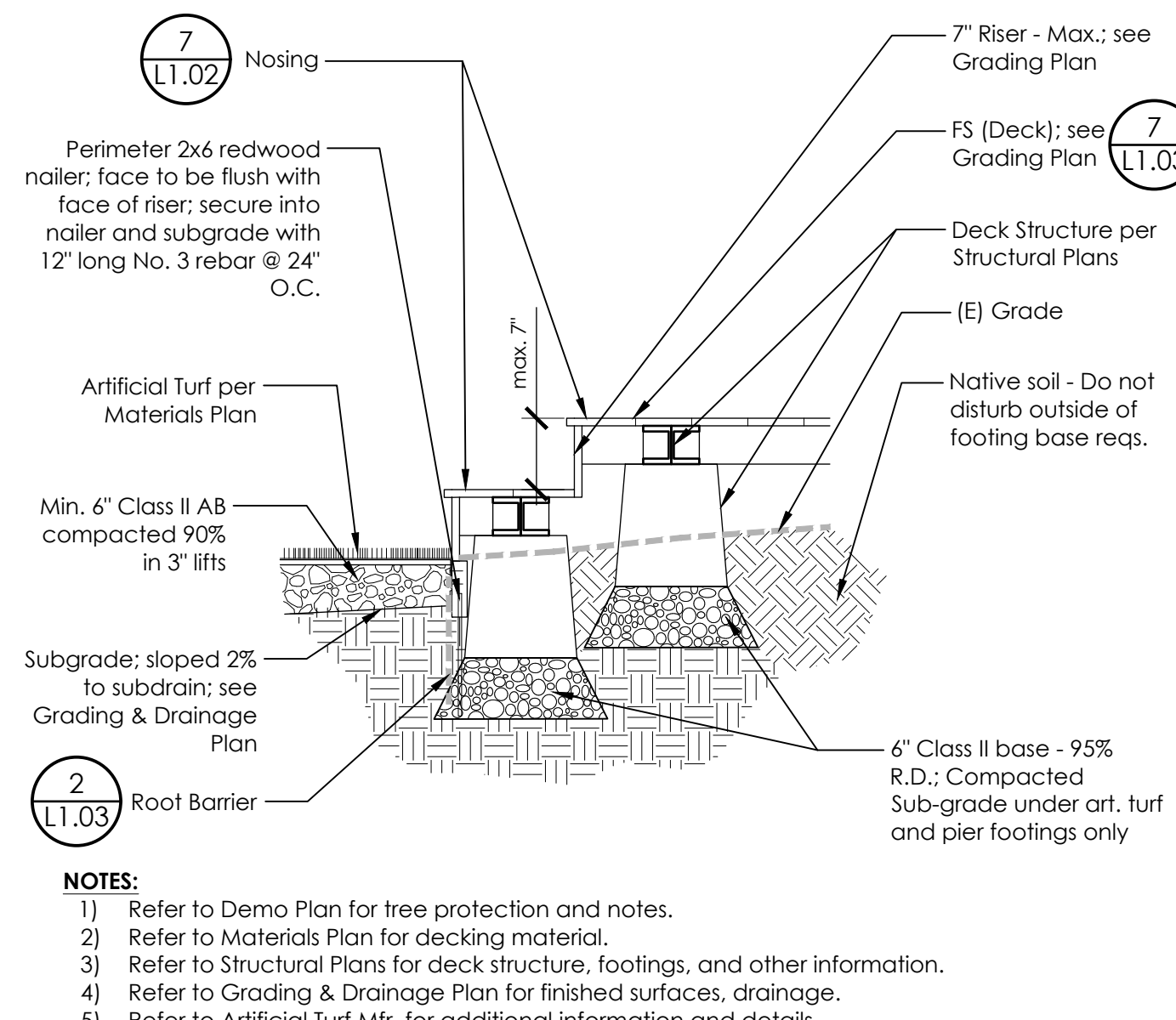

- NOTES:**
- 1) Refer to Demo Plan for tree protection and notes.
 - 2) Refer to Materials Plan for decking material.
 - 3) Refer to Structural Plans for deck structure, footings, and other information.
 - 4) Refer to Grading & Drainage Plan for finished surfaces, drainage.
 - 5) Refer to Artificial Turf Mfr. for additional information and details.

5 ARTIFICIAL TURF @ DECKING
DO NOT SCALE P-IN-SCL-22

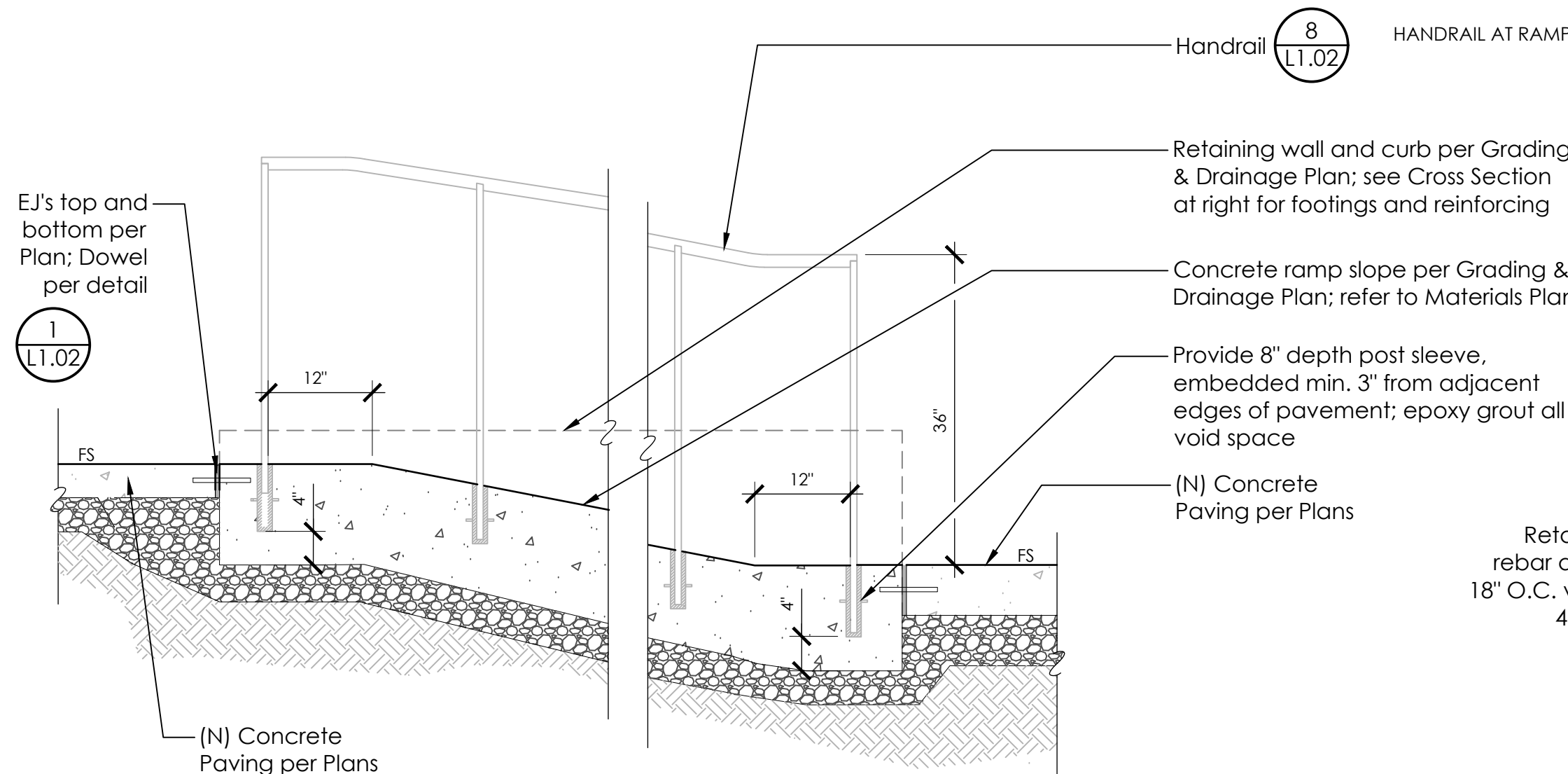

9 RAMP
DO NOT SCALE

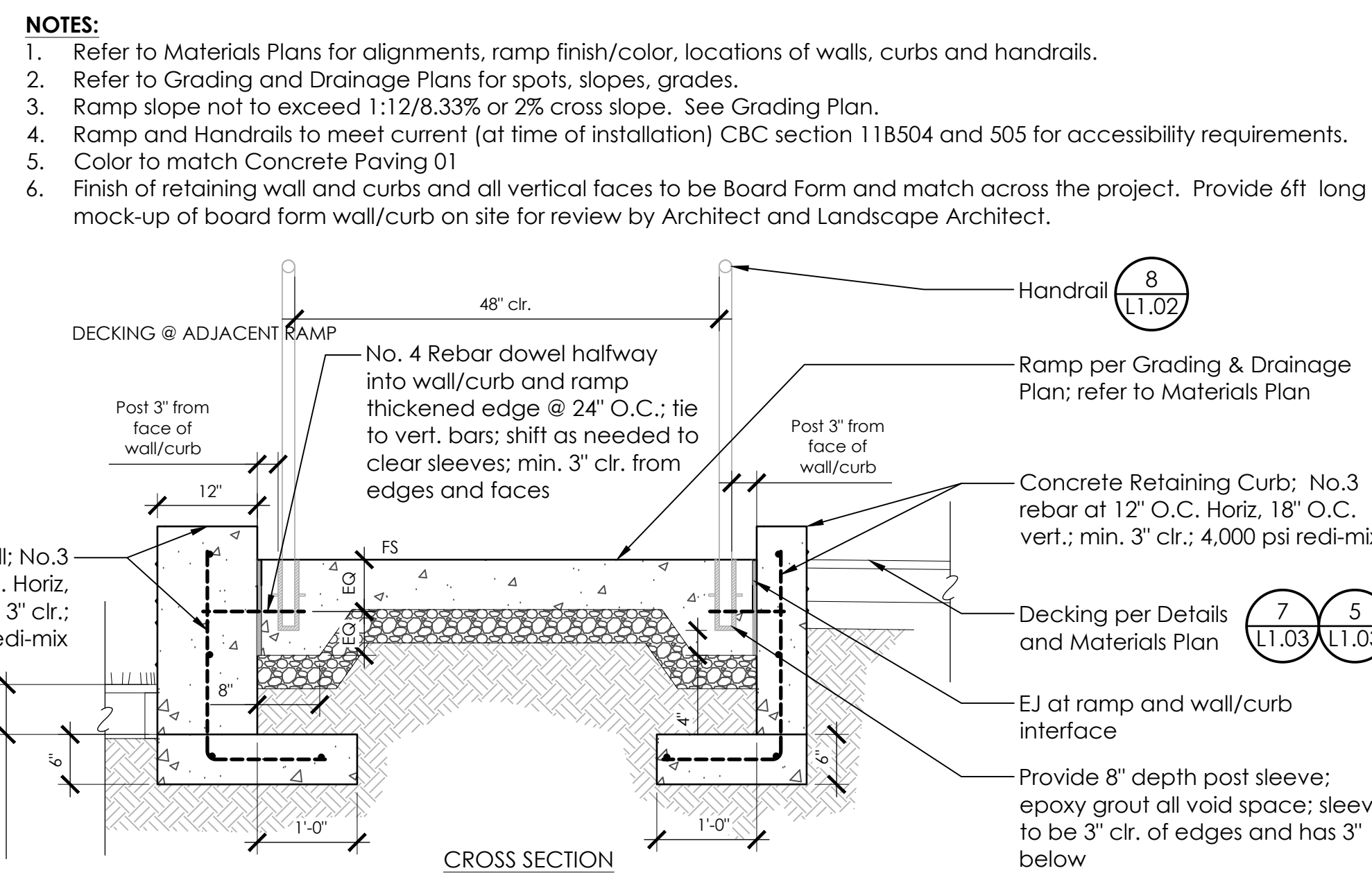

ARTIFICIAL TURF @ METAL HEADER
DO NOT SCALE P-IN-SCL-54

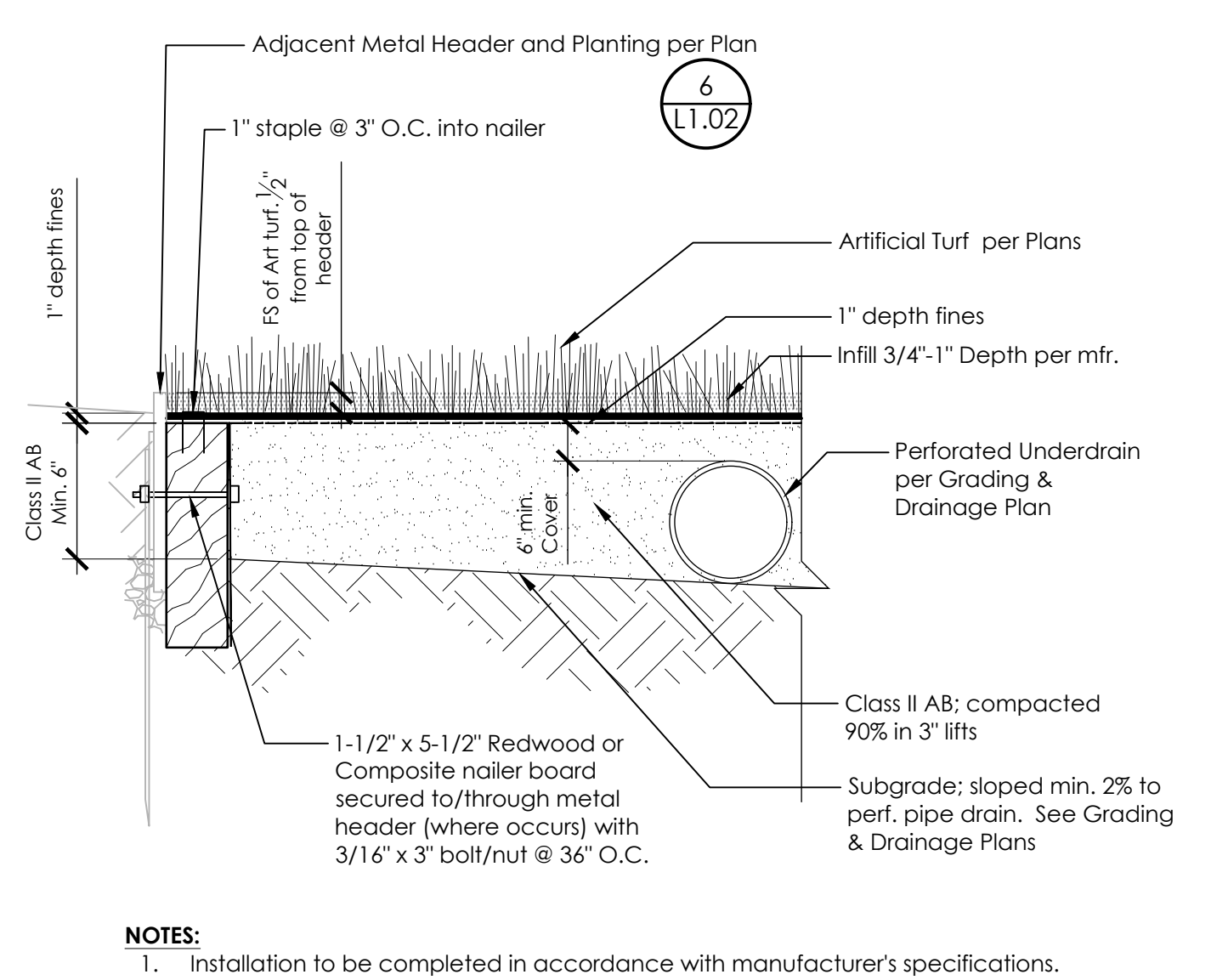

- NOTES:**
1. Installation to be completed in accordance with manufacturer's specifications.

3 ARTIFICIAL TURF @ METAL HEADER
DO NOT SCALE P-IN-SCL-54

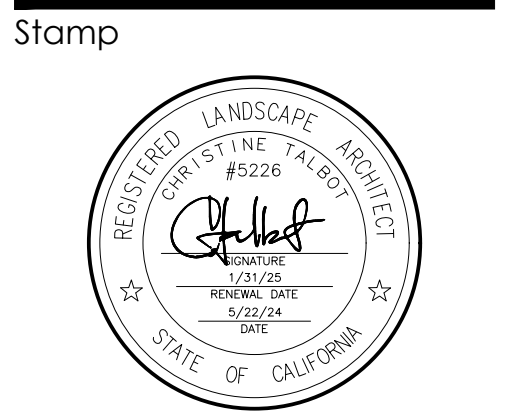

© Copyright 2018 QUADRIGA landscape architecture & planning, inc.

Issuances & Revisions

No.	Description	Date
1	Permit Re-submittal 1	08/09/24
2	Addendum 2	1-08-2025

Key Plan/Consultant Stamp

LAYOUT DETAILS

Drawn By: BNK/CT
Checked By: CT
Date: 2024/08/09
Project Number: 22-1758
Scale: AS SHOWN

L1.02